

NELSON STUD WELDING

SPECIFICATION: CHP Cupped Head Insulation Pin

CHP studs are designed to weld through and secure blanket insulation to metal heating and air-conditioning ducts, ovens, tanks, boilers, and other hot or cold equipment. The studs are welded through the insulation for a one-step attachment. The insulation blanket may be fiberglass, rock wool, or other low-density insulation.

Cupped Head Pins may also be used to anchor sprayed or gunned-on fireproofing to structural steel members in buildings to protect them from heat in the event of a fire. This protection slows the loss of structural strength to increase the time available for evacuation, and reduces the likelihood that beams will buckle or collapse.

The pins may also be welded to cellular sheet metal deck to guarantee permanent anchorage of the sprayed fireproofing which protects electrical wires running through the cells, and provides added fire resistance per UL 263 and ASTM E119 standards, Fire Tests of Building Construction and Materials. In addition to securing the fireproofing, the pins also act as a reference gauge for the thickness of fireproofing to be applied.

For similar function studs, see Nelson [TPC Single Pointed Insulation Pins](#), [P2P Double Pointed Insulation Pins](#), and [N3P Navy Type Annular Ring studs](#).

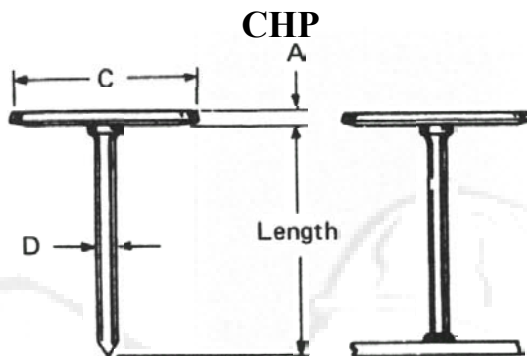

When ordering, specify Type, Description, Material, Quantity, and Part Number

Example: CHP 12 ga. x 1"; Mild Steel; 10,000 pieces; #101124100

Stud Description	Pin Diameter D	Minimum Length L	Head Diameter C	A	Required Standard Accessories	
					Chuck Assembly*	Foot Assembly
12 ga.	0.105	0.500	1.187	0.021	500015094	503011050
10 ga.	0.134	1.375	1.500	0.021	500015095	503011050

* The above chucks have a 3/8" diameter shank and need to be used with chuck adapter #521001023 to mount them on stud welding guns with female #2 Morse taper chuck adapters.

MATERIALS: CHP studs are available with Low Carbon Mild Steel shanks and galvanized sheet metal heads. For specific grade information and physical and chemical properties, conforming standards, please see [General Material Specifications](#).

Visit our website www.NelsonStudWelding.com for a list of our standard stock products.