

NELSON STUD WELDING

SPECIFICATION: N3P Navy Type Annular Ring

N3P Navy pins are welded to steel for attachment of insulation. The insulation is impaled over the welded studs and retained with caps that are driven onto the studs, and lock onto the annular rings.

The flat top caps for use with N3P pins are usually supplied in aluminum. Caps can be supplied in plated mild steel or stainless steel, if needed.

The standard N3P cap is shown below.

For similar function studs, see [Nelson P2P Double pointed Insulation Pins](#), [TPC Single Pointed Insulation Pins](#), and [CHP Cupped Head Insulation Pins](#).

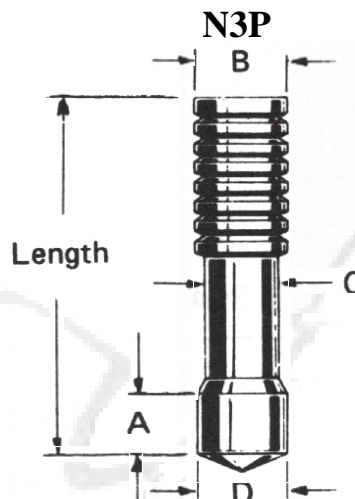

When ordering, specify **Type**, **Description**, **Material**, **Quantity**, and **Part Number**

Example: N3P 3/16 x 1"; Mild Steel; 10,000 pieces; #101074014

Stud Description	Minimum Length L	D	A	B	C	Required Standard Accessories			
						Ferrule	Chuck	Grip	Foot
3/16 x L	1.000	0.188	0.250	0.176	0.172	100101003	500001005	501001004	502001137*

* 502001137 feet used with standard duty guns.
502001001 feet used with heavy duty guns.

MATERIALS: Studs are available in Low Carbon Mild Steel and 18-8 Stainless Steel. Other materials are available by special order. For specific grade information and physical and chemical properties, conforming standards, and information on stud plating and heat treating, please [General Material Specifications](#).

Recommended Accessories:

SPECIFICATION: Cap for N3A and N3P Pins

Caps are used in conjunction with Nelson N3A and N3P pins to secure many types of insulation to steel plate.

When ordering, specify **Type**, **Description**, **Material**, and **Quantity**

Example: N3P Insulation Cap; Aluminum; 10,000 pieces

Description	Part Number
Insulation Cap	101304021

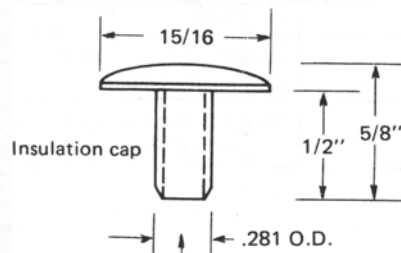

Materials: The Navy pin cap is supplied in Aluminum. For specific grade information and physical and chemical properties, and conforming standards, please see [General Material Specifications](#).

Visit our website www.NelsonStudWelding.com for a list of our standard stock products.