

NELSON STUD WELDING

SPECIFICATION: P2P Double Pointed Insulation Pin

P2P studs are stud welded to structural steel to secure blanket and board insulation to ovens, tanks, boilers, and other hot or cold equipment. The insulation may be fiberglass, rock wool, or other insulation.

P2P studs are welded using the standard stud welding process with ceramic ferrules to provide the most reliable weld strength. When used in combination with Speed Clips, the resultant system is a simple, inexpensive, and efficient method of securing insulation to metal backings.

Stud length should be longer than the insulation thickness to aid in securing Speed Clips.

For similar function studs, see Nelson [TPC Single Pointed Insulation Pins](#), [N3P navy Type Annular Ring studs](#), and [CHP Cupped Head Insulation pins](#).

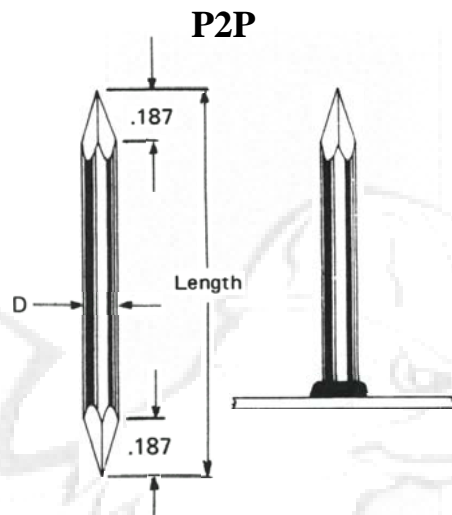

When ordering, specify **Type, Description, Material, Quantity, and Part Number**

Example: P2P 10 ga. x 1-1/2"; Mild Steel; 10,000 pieces; #101126150

Stud Description	Pin Diameter D	Minimum Length L	Required Standard Accessories			
			Ferrule	Grip	Chuck	Foot*
10 ga.	0.134	1.000	100101002	501001003	500001002	502001137

MATERIALS: Studs are available in Low Carbon Mild Steel and 18-8 Stainless Steel. Other materials are available by special order. For specific grade information and physical and chemical properties, conforming standards, and information on stud plating and heat treating, please see [General Material Specifications](#).

Recommended Accessories:

SPECIFICATION: Speed Clips

Speed clips, when used in combination with P2P studs, secure all types of material that can be readily impaled: fiberglass, foam, felts, and corks, as well as refractory linings and light-density insulation board.

When ordering, specify **Type, Description, Material, and Quantity**

Example: Speed Clip 10 ga. x 1-1/2" Round; Stainless Steel; 10,000 pieces; #101301084

Clip Description	Pin Size C	Clip Diameter D	Clip Thickness
Round	10ga.	1-1/2	0.021
Round	10ga.	2	0.021
Square	10ga.	1-1/2	0.021
Square	10ga.	2-1/2	0.021
Rectangular	10ga.	1 x 1-1/4	0.021

Rectangular/Square Impression Clip

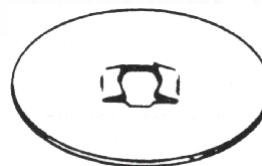
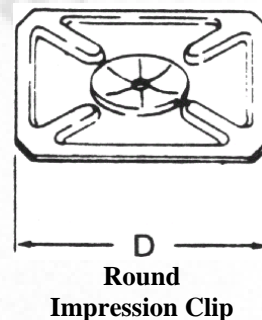

Visit our website www.NelsonStudWelding.com for a list of our standard stock products.



MATERIALS: Speed Clips are available in zinc plated Low Carbon Mild Steel and 18-8 Stainless Steel. Other materials are available by special order. For specific grade information and physical and chemical properties, conforming standards, and information on stud plating and heat treating, please see [General Material Specifications](#).

Visit our website www.NelsonStudWelding.com for a list of our standard stock products.

Nelson Stud Welding, Inc.
7900 West Ridge Road
Elyria, Ohio 44035

PH 1-800-NEL-WELD
1-800-635-9353

E-mail: Nelson.Sales@NelsonStud.com