

NELSON STUD WELDING

SPECIFICATION: Metric **ATC, ATS, ATA**
Threaded Stored Arc® Studs

Nelson metric Stored Arc ATC, ATS, and ATA studs are designed to be welded to thin gauge sheet metal using either the Stored-Arc® method of stud welding, or a transformer/rectifier power-control source in the short-cycle mode. These applications generally provide a weld bond that is greater than the strength of the sheet to which they are welded.

Nelson Stored Arc studs have a flanged weld base that is about 1mm greater than the nominal stud diameter. The “A” flange allows automatic stud feeding for increased production speeds. The flange also increases the stress area on the sheet. Standard studs are fully threaded, and come in lengths up to 32mm.

Mild steel studs are copper flash plated, stainless studs are passivated, and aluminum studs are acid etched for superior weld results.

For similar function metric studs, see Nelson **ANC**

Unthreaded Stored Arc® studs, AXC “Fir Tree” studs, Grounding studs, H8X “T” studs, and “W” Top Wide Flange studs. In the imperial line of Nelson studs, see **TATC Auto-Feed Capacitor Discharge studs.**

Check Standard Stock

ATC, ATS, ATA

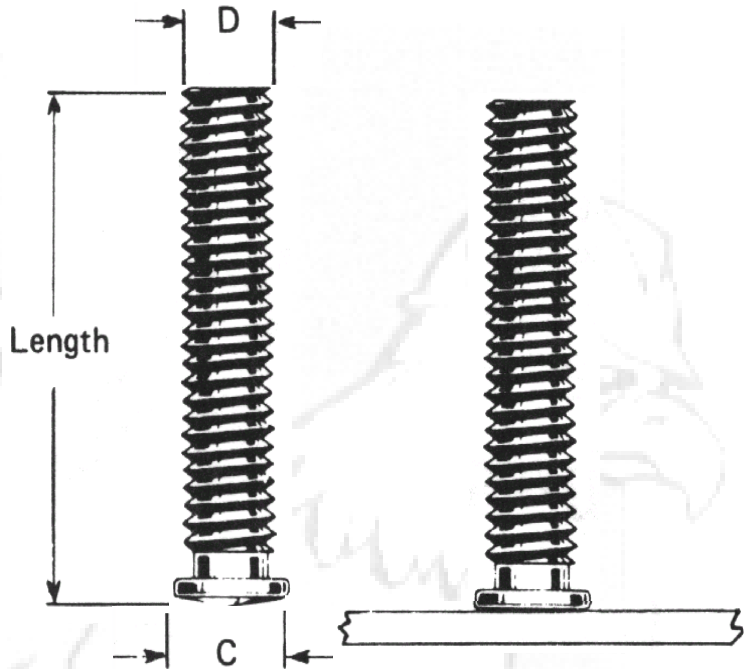

When ordering, specify Type, Description, Material, Quantity, and Part Number

Example: ATC M6 x 16mm; Mild Steel; 10,000 pieces; #101228124

Thread Size	Stud Diameter D	Flange Diameter C	Minimum Length L*	Required Standard Accessories		
				Chuck	Foot	Spark Shield
M3 x 0.50	3.00	5.00	8.00	500001135	502001137	511001108
M4 x 0.70	4.00	6.00	8.00	500001003	502001137	511001108
M5 x 0.80	5.00	7.00	8.00	500001005	502001137	511001108
M6 x 1.00	6.00	8.00	10.00	500001267	502001137	511001108
M8 x 1.25	8.00	10.00	12.00	500001009	502001137	511001108

MATERIALS: Studs are available in Low Carbon Mild Steel (ATC), Stainless Steel (ATS), and 1100 Aluminum (ATA). Some materials may be available by special order. For specific grade information and physical and chemical properties, conforming standards, and information on stud plating and heat treating, please see **General Material Specifications.**

THREADS: Standard metric threads meet ISO 6g.

***AUTO FEED:** For automatic feed applications, stud length must be a minimum of 1-1/2 times the flange diameter. Studs to be used in automatic feed systems must be 100% sorted (Auto Feed quality). Therefore, “Auto Feed (AF) Quality” must be requested and specified at time of quotation and order entry.

Visit our website www.NelsonStudWelding.com for a list of our standard stock products.