

NELSON STUD WELDING

SPECIFICATION: L2L Lagging Stud with Hole



L2L studs are welded to hot work, such as furnaces, kilns, ducts, or tanks. They are intended to attach of insulation blanket using wires or “gull wing” wire skewers.

Nelson L2L studs are also welded around openings in plates for retention of cover plates with wedge pins inserted through the slots.

For similar function studs, see Nelson **R6P Rectangular Slotted studs**, **E2L “Eyebolt” studs**, and **R7P Rectangular Studs with Hole**.

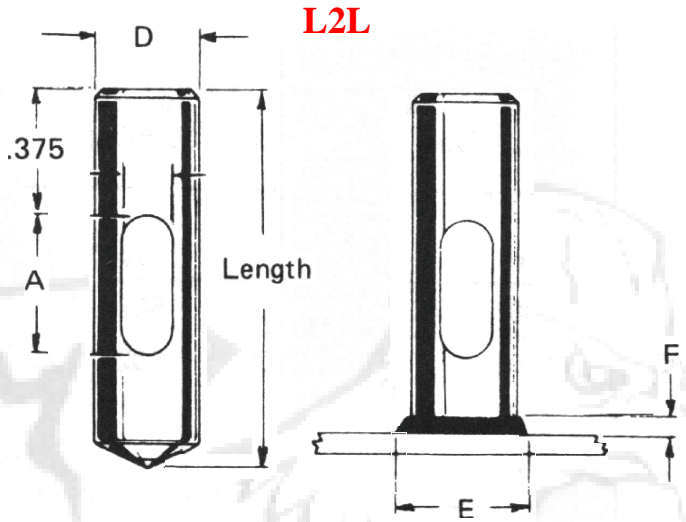

When ordering, specify Type, Description, Material, Quantity, and Part Number

Example: L2L 3/8 x 1-1/2”; Mild Steel; 10,000 pieces; #101060013

Stud Description	Stud Diameter D	A	B	Weld Fillet Diameter		Required Standard Accessories			
				E	F	Ferrule	Chuck Assembly	Foot*	Grip
3/8 x L	0.375	0.500	0.156	0.500	0.125	100101099	500001011	502001137	501001009

* 502001137 foot is used with standard duty guns.
502001001 foot is used with heavy duty guns.

MATERIALS: Studs are available in Low Carbon Mild Steel and 18-8 Stainless Steel. For specific grade information and physical and chemical properties, conforming standards, and information on stud plating and heat treating, please see **General Material Specifications**.

FLUX: All Nelson L2L studs have a solid flux load.

Visit our website www.NelsonStudWelding.com for a list of our standard stock products.