

NELSON STUD WELDING

SPECIFICATION: S6L Sprinkler Studs

S6L Studs are internally threaded studs with a reduced weld base. They are named for their primary application, which is the attachment of hangers to hold piping for overhead sprinkler systems.

Nelson S6L studs are not solely used for sprinkler systems, and are applicable to many other mounting applications.

For a similar function stud, see Nelson [TBL Internally Threaded studs](#), [SBA Aluminum Shoulder studs](#), and [SBL Shoulder studs](#).

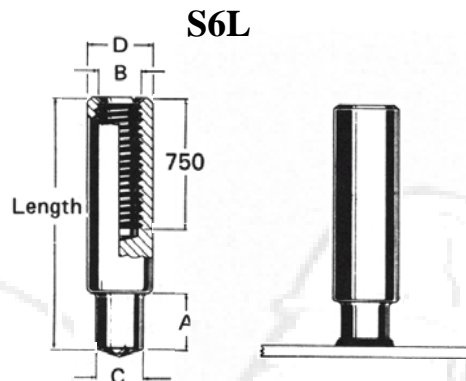

When ordering, specify **Type**, **Diameter**, **Before Weld Length**, **Material**, **Quantity**, and **Part Number**
Example: CPL 3/8-16 x 2"; Mild Steel; 10,000 pieces; #101101006

Major Diameter D	A	Tap Diameter B	Weld Base Diameter C	Length L	Ferrule	Required Standard Accessories		
						Ferrule Grip	Chuck	Foot
1/2	0.437	3/8-16	0.375	2.000	100101031	501001008	500001014	502001137
5/8	0.500	1/2-13	0.437	2.000	100101032	501001009	500001016	502001138
3/4	0.687	5/8-11	0.500	2.000	100101033	501001011	500001018	502001138
7/8	0.687	3/4-10	0.500	2.000	100101119	501001012	500001019	502001138

MATERIALS: Studs are available in Low Carbon Mild Steel and 18-8 Stainless Steel. Other materials are available by special order. For specific grade information and physical and chemical properties, conforming standards, and information on stud plating and heat treating, please see [General Material Specifications](#).

THREADS: These threads can be internally tapped. Standard internal threads are typically UNC-2B.

FLUX: All Nelson S6L studs have a solid flux load.

Visit our website www.NelsonStudWelding.com for a list of our standard stock products.